

ASTRO-TECH AT80LE

from Astronomy Technologies

Thank you for choosing our Astro-Tech **AT80LE** high-performance apochromatic doublet ED refractor.

Its carbon fiber tube and dew shield are exceptionally durable, with excellent thermal characteristics. The dew shield is oversized, with a 124mm o.d. compared to the 80mm lens diameter.

This assures that tube currents, which typically follow the walls of a telescope tube, will have a minimal effect on your images as the AT80LE cools down to ambient temperature. You can begin serious observing with an AT80LE sooner than you can with an aluminum tube 80mm doublet with a conventional dew shield design.

The images from the AT80LE's fully-multicoated 480mm f/6 ED doublet optical system (using premium Ohara glass and an FPL-53 extra-low dispersion element) are virtually color-free, even at very high magnifications. We believe you will find that the visual and photographic performance of your AT80LE doublet is little short of remarkable.

This instruction sheet will provide you with information on how to get the most out of your new refractor, and how to properly maintain your scope so it can give you a lifetime of observing enjoyment.

Please familiarize yourself with your telescope's parts and functions before operating it for the first time.

PARTS OF THE AT80LE

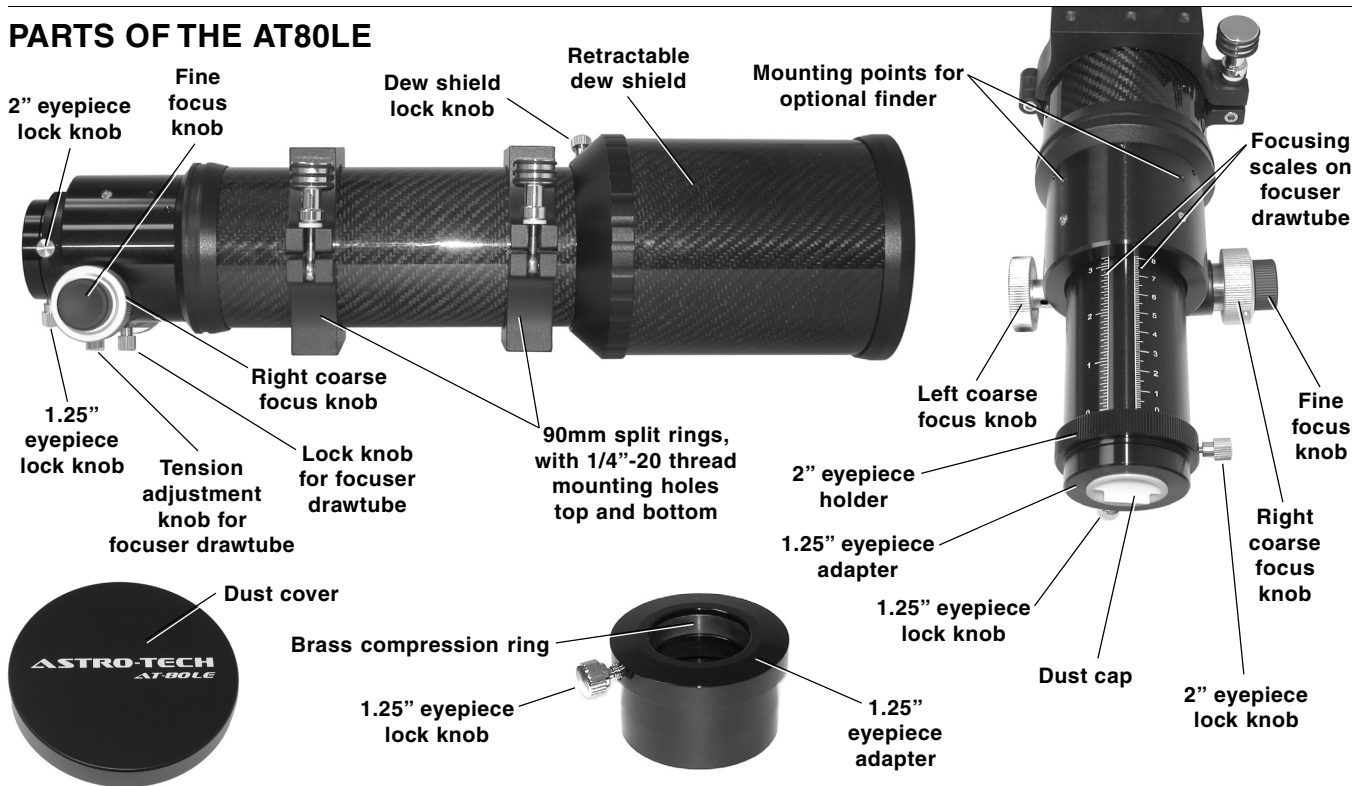

Astro-Tech AT80LE Refractor Specifications

Aperture 80mm (3.1")
Focal Length 480mm
Focal Ratio f/6
Objective Type doublet using Ohara FPL-53 glass
Optical Coatings fully multicoated
Resolving Power (Dawes' Limit) 1.45 arc seconds
Visual Limiting Magnitude 12.0 maximum
Light Grasp (versus the eye) 131x
Field Stops ... 2 glare-reducing baffles in optical tube, one at front of dew shield
Focuser dual-speed Crayford-style with 10:1 reduction ratio fine focus; 2" and 1.25" compression ring eyepiece holders
Focuser Travel 2.9" (74mm), with millimeter and inch scales on drawtube for repeatable focus
Optical Tube Material carbon fiber

Optical Tube Diameter 90mm o. d.
Tube Length (lens shade retracted) 15.5" (394mm)
Tube Length (lens shade extended) 18.75" (476mm)
Weight (optical tube only) 5.15 lbs. (2.34 kg)
Weight (with rings and 1.25" adapter) ... 6.55 lbs. (2.98 kg)
Lens Shade ... retractable carbon fiber, with lock knob
Objective Lens Cover slip-on metal
Mounting Rings dual 90mm felt-lined hinged split rings with 1/4"-20 thread mounting holes
Case aluminum-frame foam-fitted lockable hard case, with carrying handle
Case Dimensions 20" x 7.5" x 9"
Lowest Usable Power 12x (40mm eyepiece)
Highest Terrestrial Power 80x (6mm eyepiece)
Highest Practical Power 160x (3mm eyepiece)
Theoretical Maximum 160x (3mm eyepiece)

Your **Astro-Tech AT80LE** refractor is usable for day and night viewing, simply by adding a star diagonal and eyepiece. Any brand of eyepiece can be used, from a 40mm for the lowest useful magnification (12x) to a 3mm (160x) for high power use. A 2" compression ring eyepiece holder on the focuser drawtube and a supplied 1.25" compression ring eyepiece adapter let you use either a 2" or 1.25" star diagonal with no other adapter needed.

The focal length of the AT80LE is ideal for low to medium power wide-angle views of nebulas, open star clusters, large galaxies, and comets. Crisp and detailed views of the Moon, planets, binary stars, and globular star clusters are also routine at magnifications of 120x to 160x when seeing conditions permit.

To calculate the magnification of your telescope and eyepiece combination, divide the telescope focal length in mm by the eyepiece focal length in mm. For example, a 6mm eyepiece in the AT80LE will give you a magnification of 80x (480mm/6mm = 80).

Astronomical Observing: The theoretical maximum usable power available from this telescope is 160x. This requires a 3mm eyepiece that provides a narrow and quite dim 0.5mm exit pupil. A more practical maximum magnification for astronomical viewing with the AT80LE might be 120x, using a 4mm eyepiece. Keep in mind that seeing conditions play an important role in how high a magnification you can use on any given night. Only good seeing conditions (clear skies and calm air) will support viewing at 160x. Under less than ideal conditions, lower powers in the 80x to 120x range provide more consistently usable and pleasing images.

The widest possible field of view with a 1.25" eyepiece is about 3.5°, which can be achieved with a 12x (40mm) Plössl eyepiece. Fields of view of as much as 5.5° can be achieved with 2" wide field eyepieces of a similar focal length.

While the AT80LE has not been specifically designed for astrophotography, it does an outstanding job as a wide-field astrograph for casual 35mm and CCD imaging. Their are two chrome thumbscrews under the focuser. The front thumbscrew lets you lock in a sharp focus for photography. The rear thumbscrew of the pair lets you adjust the tension on the focuser drawtube to keep heavy 2" diagonals and eyepieces from accidentally slipping out of focus due to their weight when the AT80LE is aimed at the zenith.

Terrestrial Observing: The AT80LE works well for daytime birding, nature studies, sweeping the landscape from the home with a view, etc. It is also a very good 480mm (9.6x) f/6 telephoto lens for terrestrial photography. Generally speaking, the maximum usable daytime power with any terrestrial scope is about 1x per mm of aperture (80x with a 6mm eyepiece in the AT80LE). Attempts to push the daytime power beyond 80x often magnify the heat waves, dust, and "mirage" in our atmosphere to the point where the images become blurry and unusable. A 20x (24mm) to 53x (9mm) eyepiece is usually more satisfying for everyday terrestrial use than an 80x.

Mounting the AT80LE: A stable tripod or astronomical mount is essential for best viewing. The scope is supplied dual hinged 90mm split rings that will allow you to install your scope on an equatorial mount of your choice for extended astronomical observing. Adding an optional Vixen-style dovetail bar to the rings will let you mount your AT80LE on a suitably-sturdy altazimuth mount for terrestrial observing and casual grab-and-go backyard astronomy.

Astro-Tech makes just such an altazimuth mount, the exceptionally stable and highly-reviewed Astro-Tech Voyager. With a 20 lb. payload capacity, the Voyager can easily support the 6.5 lb. AT80LE. The adjustable-height Voyager has automatic-clutch worm gear manual slow motion controls in both altitude and azimuth to make tracking terrestrial and astronomical objects smooth and easy.

The AT80LE is light enough to be used on any good quality heavy duty camera tripod by adding an optional Vixen-style dovetail bar to the rings. These dovetails generally have a centrally-positioned 1/4"-20 thread hole that will connect directly to the 1/4"-20 thread mounting bolt on a camera tripod's pan head.

Optional Astro-Tech Accessories: Astro-Tech makes 1.25" and 2" star diagonals with state-of-the-art 99% reflectivity dielectric coatings that nicely complement the performance of the AT80LE. These diagonals are available from your Astro-Tech dealer to provide the

maximum possible reflectivity and planetary detail.

An Astro-Tech 45° viewing angle image-erecting 1.25" diagonal is available for terrestrial observing.

An inexpensive non-magnifying Astro-Tech illuminated multiple reticle finder is also available. It mounts on the front of the AT80LE focuser, using either of the pre-drilled mounting holes provided.

Caring for Your Scope Optics: Never store the telescope in a damp or humid environment. Avoid leaving it in a hot environment (exposed to direct sunlight on a window sill, in a car trunk, etc.) If you must store it in high humidity conditions, put a few packets of desiccant (silica gel or the equivalent, available from most camera stores) in with the telescope to absorb excess moisture. If not properly stored in a humid environment, the telescope may develop mildew which can damage the optics.

If dew has formed on the scope after a night of observing, allow the optics to air dry at room temperature before putting the lens cover on the scope and storing it away.

If the front lens surface becomes dusty, smeared, or shows fingerprints or any other surface build-up, clean the lens using the following technique. First, gently blow away any surface dust or particles with a clean air blower (a child's ear syringe or a photographer's camel's hair brush with attached blower bulb, for example). Using canned or compressed air is not recommended, as the propellant in the can may spit out and leave difficult-to-remove deposits on the lens surface.

Second, moisten a cloth with a few drops of a photographic-quality optical cleaning solution designed for multicoated camera and binocular lenses. A well-worn cotton handkerchief works well and Zeiss and Kodak both make suitable fluids. Do not drip the cleaning fluid directly on the lens. Use the barely damp (not wet) cloth to gently wipe the lens surface clean, turning the cloth frequently to always keep a clean portion of the cloth in contact with the lens. Blot the lens dry with a dry portion of the cleaning cloth or a separate cloth. Start with a clean cloth each time cleaning is needed.

Avoid overcleaning your scope. The multicoatings on the lens are quite hard and durable. However, frequent overzealous cleaning can scratch the coatings if all the dust particles (which are often tiny flecks of windborne rock) are not removed before you start pushing a damp cloth around the lens surface. A few specks of debris on the lens will not be visible in your images. They are not in the focal plane and don't block enough light to measure, let alone be seen. Clean your optics only when absolutely necessary. If you take proper care of your scope, cleaning should rarely be needed.

Caring for Your Scope Finish: The clear coat finish on the carbon fiber optical tube and dew shield of the AT80LE is extremely durable, but can potentially become scratched if abrasive cleaners are used to clean it. The scope can become smudged with fingerprints during use, but these will not harm the optical tube finish, nor the anodized finish on the aluminum focuser body and trim rings. A clean soft cloth slightly dampened with plain water (or a little moisture from your breath and a quick wipe with a clean handkerchief) is generally enough to remove fingerprints. Avoid abrasive cleaners, harsh chemical cleaners, or organic solvents like benzene, alcohol, etc., as these may ruin the finish. They can certainly affect the optical coatings if they accidentally drip or splash on the objective lens.

Never use the telescope in the rain or in conditions where it may get wet. The telescope is not waterproof. Nighttime dew will not harm the scope, but if the telescope accidentally gets caught in the rain, immediately wipe off all water using a clean and dry soft cloth. If the telescope gets totally soaked in water, or submerged, immediately contact your dealer for service instructions. Do not disassemble or attempt to repair your telescope yourself, as this violates the terms of the limited product warranty, and negates any guarantee.

Caution! Never directly view the Sun with your telescope! Never aim your AT80LE at the Sun without having a professionally-manufactured solar filter mounted over the objective lens. Viewing the Sun through the scope without the proper protection for even a moment may result in permanent severe damage to your eyes, and can even cause blindness. Contact your Astro-Tech dealer if you are interested in purchasing a compatible professional solar filter.

 **ASTRO-TECH** www.astronomytechnologies.com
from Astronomy Technologies, 680 24th Avenue SW, Norman, OK 73069