

***CELESTRON***®

- **C80-HD Refractor Telescope**
- **C102-HD Refractor Telescope**
- **C114-HD Reflector Telescope**
- **C150-HD Reflector Telescope**
- **CG-4 Equatorial Mount**

**Models #21077 / #21016 / #31027 / #31056 / #91510**

---

**INSTRUCTION MANUAL**

## IDENTIFYING PARTS OF FIGURE 1

1. Star Diagonal (Refractors only)	13. Latitude Scale
2. Eyepiece	14. Altitude Adjustment Screw
3. Finderscope	15. Tripod Mounting Head
4. Finder Bracket	16. Tripod
5. Focuser	17. Tripod Support Brace
6. Tube Rings	18. Counterweight Shaft
7. Objective Cap	19. Counterweight(s)
8. Optical Tube Platform	20. Azimuth Adjustment Screw
9. DEC Setting Circle	21. R.A. Slow Motion Knob
10. R.A. Clamp	22. DEC Clamp
11. R.A. Setting Circle	23. DEC Slow Motion Knob
12. Polar Finder (Optional)	24. Accessory Tray
	25. Accessory Tray Mounting Screws

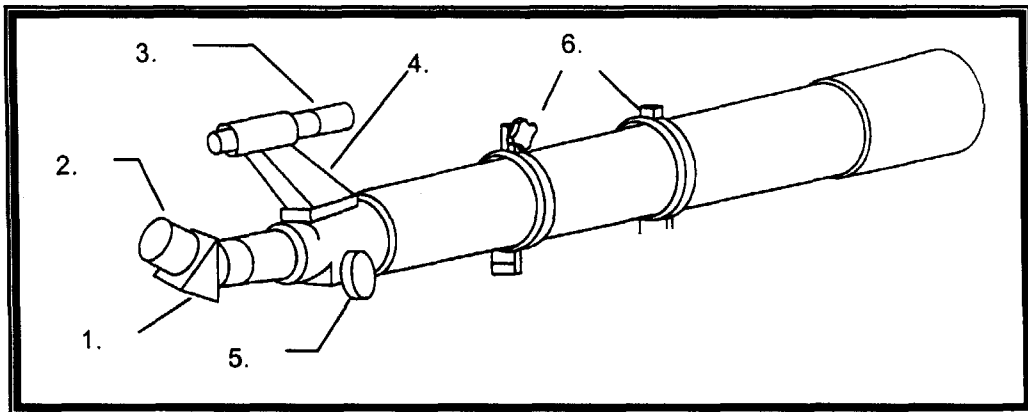

**Figure 1A**  
C80-HD & C102-HD

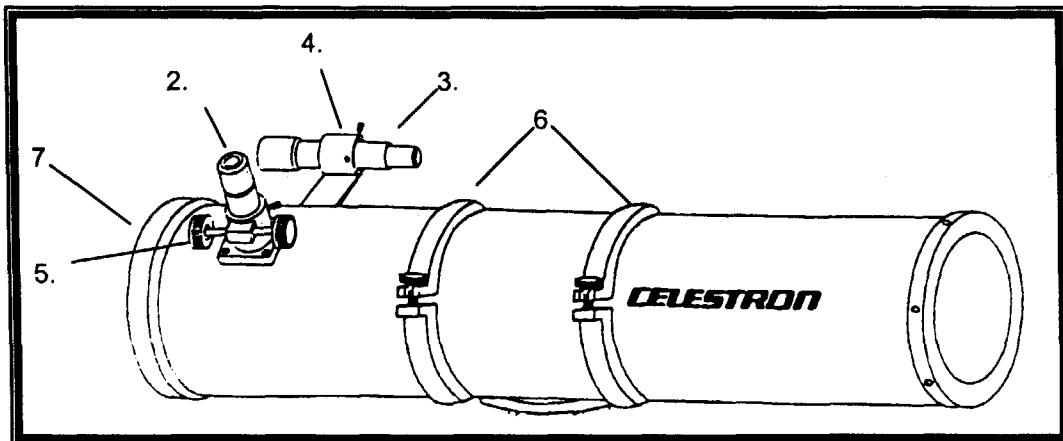

**Figure 1B**  
C114-HD & C150-HD

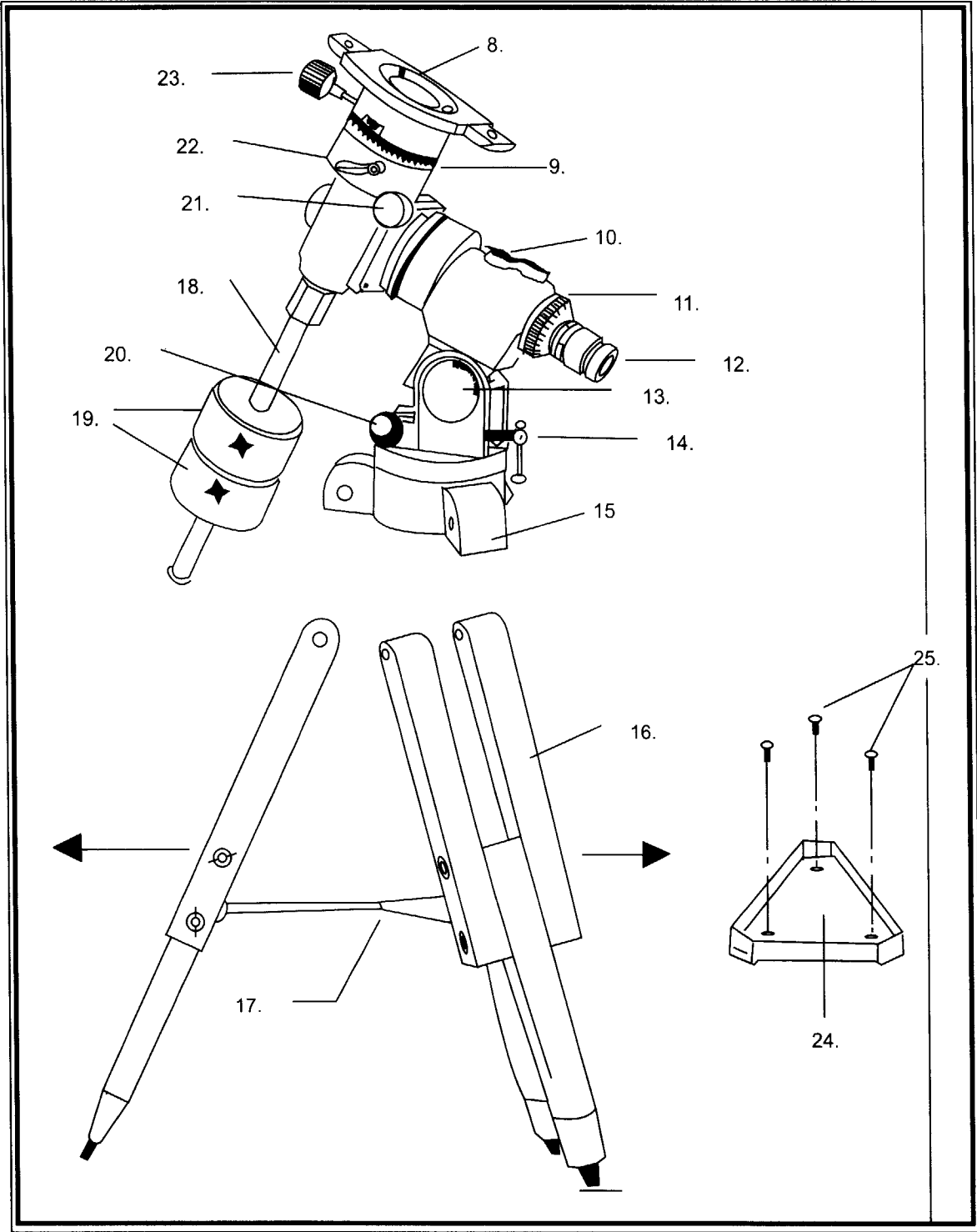

**Figure 1C**  
**CG-4 EQ Mount**

## INTRODUCTION

Congratulations on your purchase and welcome to the **Celestron** world of astronomy. If you're a newcomer to the hobby of astronomy, some of the terms and telescope components described in this instruction manual may be new to you. This manual is designed to instruct you in the proper use of your Celestron C80-HD Refractor, C102-HD Refractor, C114-HD 4.5 Newtonian or C150-HD Newtonian as well as the CG-4 Equatorial Mount. To assist you in assembling and operating your telescope, take time to review this manual and the parts diagram listed on Figure 1.

**WARNING—NEVER LOOK AT THE SUN WITH YOUR TELESCOPE OR ITS FINDERSCOPE. PERMANENT AND IRREVERSIBLE EYE DAMAGE MAY RESULT AS WELL AS DAMAGE TO YOUR TELESCOPE.**

**HOWEVER, YOU MAY ENJOY LOOKING AT THE SUN IF YOU HAVE A SAFE METHOD OF DOING SO—A MYLAR SOLAR FILTER. IF USING THE MYLAR SOLAR FILTER, MAKE SURE THE FINDERSCOPE IS COVERED.**

## TELESCOPE ASSEMBLY

The telescopes and all items are packed in one box. Included are:

- Telescope Optical Tube
- German Equatorial Mount
- Adjustable Aluminum tripod
- 6x30 Finderscope and Bracket
- Counterweight Shaft and Counterweights (3.6 Kg and 1.8 Kg for reflector models #31027, #31056 and refractor model #21016; 3.6 kg only for refractor model #21077 and CG-4 Eq Mount #91510)
- Tripod Accessory Tray
- Declination Slow Motion Knob
- Right Ascension Slow Motion Knob
- 20mm Plossl Eyepiece
- 1 1/4" Mirror Diagonal (Except #31027 & #31056)

### Setting Up the Tripod:

1. Locate the tripod head (see figure 1). Attach each leg one by one to the tripod head by aligning the holes at the top of each leg with the holes in the tripod head. Slide a bolt through each of the legs and the tripod head and secure at the other end with a wing nut.
2. Now that the tripod legs are attached, stand the tripod up and spread the legs until the center leg support is fully extended.
3. The equatorial mount, which holds the telescope, attaches to the tripod head. On one side of the tripod head there is an "N" which signifies North. This side of the tripod will face north when setting up for an astronomical observing session. Above the "N" is a metal peg about 3/4" high that points straight up. Place the equatorial mount head on top of the tripod head so that the metal peg fits between the two azimuth adjustment bolts. It may be necessary to partially unscrew the bolts to allow the metal peg to fully extend into the altazimuth housing.
4. Tighten the knob located on the underside of the tripod head. This will hold the equatorial mount firmly to the tripod head.

## **Attaching the Accessory Tray**

Next, attach the accessory tray to the tripod. Locate the accessory tray and the three wingnut screws to attach the tray.

1. Place the accessory tray on the center support brace of the tripod and align the holes on the tray with those on the support brace.
2. Insert the wingnut screws through the bottom of the tripod support brace and thread them into the accessory tray holes.

With the accessory tray in place, the tripod will be much more stable, making it easier to attach the telescope.

## **Installing the Counterweight Bar**

With the mount securely in place, you are ready to attach some of the accessories (the telescope tube will be added last). Start with the Counterweight Bar and Counterweights. Used to balance the telescope, the Counterweight Bar attaches to the opposite side of the mount as the telescope. To install the Counterweight Bar:

1. Retract the counterweight bar lock nut by turning it counterclockwise. This will expose the threads on the end of the Counterweight Bar.
2. Thread the Counterweight Bar into the mount completely. It threads into the mount opposite the telescope.
3. Tighten the lock nut fully for added support.

The Counterweight Bar is now installed.

## **Installing the Counterweights**

With the counterweight bar in place, you are ready to attach the counterweights.

1. Remove the safety thumbscrew on the end of the counterweight bar.
2. Loosen the counterweight lock screw (on the counterweight itself) so that the central hole of the counterweight is unobstructed.
3. Slide the counterweight onto the counterweight bar. Move it high enough to allow room for the second weight (if included).
4. Tighten the counterweight lock screw to hold it in position.
5. Repeat this process for the second weight.
6. Replace the thumbscrew on the end of the counterweight bar. The thumbscrew will prevent the counterweight(s) from sliding off the bar should they ever become loose.

## **Attaching the Optical Tube**

Before you attach the optical tube, make sure that the declination and right ascension clamps are tight. The optical tube attaches to the mount via two rings that are mounted on the tube of the telescope. To mount the telescope tube:

1. Loosen the knobs on the side of the rings. This will allow you to slide the mounting rings the length of the optical tube.
2. Locate the two screws on either end of the platform for the optical tube (#8).
3. Hold the telescope up to the mount and slide the mounting rings until they are over the screws on the mounting platform.
4. Place the flat portion of the ring over the mount so that the hole in the ring is over the screw protruding out of the mounting platform.
5. Tighten the knobs underneath the mounting platform to secure the rings.
6. Tighten the knobs on the side of the mounting rings to prevent the telescope from sliding forward or backward. These can be loosened later to reposition the telescope during the balancing process.

### Balancing the Telescope

To eliminate undue stress on the mount, the telescope should be properly balanced around the polar axis. In addition, proper balancing is crucial for accurate tracking if using a clock drive. To balance the mount:

1. Release the R.A. Clamp and position the telescope off to one side of the mount (see figure 2a).
2. **GRADUALLY** release the telescope to see which way it "rolls."
3. Loosen a counterweight lock screw and slide the counterweight to a point where it balances the scope (i.e., the telescope remains stationary when the R.A. clamp is released).
4. Tighten the counterweight lock screw.

The scope is properly balanced in right ascension.

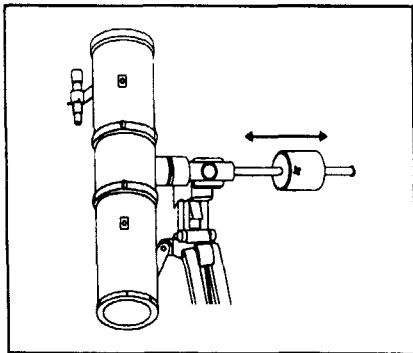

Figure 2a

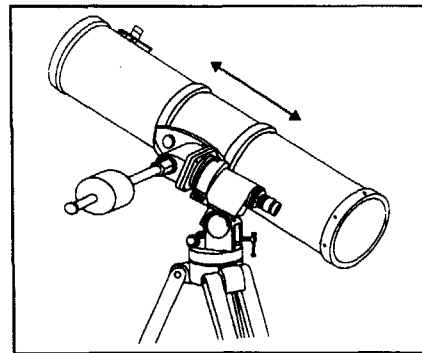

Figure 2b

The telescope should also be balanced in declination to prevent any sudden movement when the Declination clamp is released. To balance the telescope in Declination:

1. Release the R.A. clamp and rotate the telescope so that it is on one side of the mount (i.e., as described above for balancing the mount in R.A.).
2. Lock the R.A. clamp to hold the telescope in place.
3. Release the DEC clamp and position the telescope so that it is parallel to the ground.

4. **GRADUALLY** release the telescope tube to see which way it "rolls."
5. Loosen the screws that hold the telescope inside the mounting rings and slide the telescope either forward or backwards until it remains stationary when the DEC clamp is released (see figure 2b).
6. Tighten the screws that hold the telescope in the mounting rings.

The telescope is now properly balanced in declination.

#### **Attaching the Finderscope (for #21077, #21016 & #31056)**

To install the finderscope onto the telescope you must first mount the finderscope through the finder bracket and then attach it to the telescope. Toward the front of the telescope tube, near the focusing assembly, there is a small bracket with a set screw in it. This is where the finderscope bracket will be mounted. To install the finderscope:

1. Slide the rubber O-ring over the eyepiece end of the finderscope and roll it 2/3 of the way up the finderscope.
2. Insert the eyepiece end of the finderscope through the bracket until the O-ring presses tightly between the finder and the inside of the bracket.
3. Tighten the three adjustment screws until they make contact with the finderscope body.
4. Locate the mounting bracket near the front (open) end of the telescope.
5. Loosen the set screw on the mounting bracket on the telescope.
6. Slide the finder bracket (attached to the finderscope) into the mounting bracket on the telescope.
7. The finderscope bracket will slide in from the back. The finderscope should be oriented so that the objective lens is toward the front (open) end of the telescope (see figure 3).
8. Tighten the set screw on the mounting bracket to hold the finderscope in place.

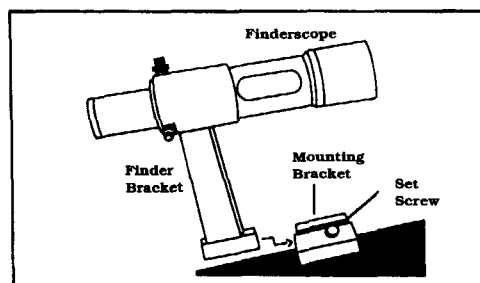

Figure 3

#### **Attaching the Finderscope (for #31027)**

1. Remove the nuts from the studs where the finderscope will mount (see figure 4).
2. Mount the finderscope bracket (#4) by mounting the bracket over the studs protruding from the tube and tightening it down with the supplied nuts.

3. Slide the rubber O-ring over the eyepiece end of the finderscope and roll it 2/3 of the way up the finderscope.
4. Insert the eyepiece end of the finderscope through the bracket until the O-ring presses tightly between the finder and the inside of the bracket.
5. Tighten the three adjustment screws until they make contact with the finderscope body.

The finderscope is now installed and only needs to be aligned before it is used.

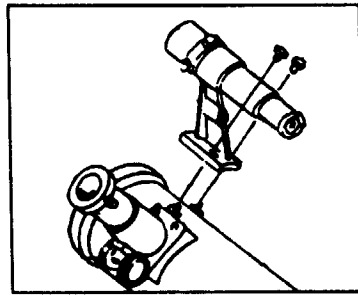

Figure 4

### Attaching the Accessories

In order to use your telescope there are some standard accessories which must first be installed: The installation of each is described

**1 ¼" Diagonal (for #21077 & #21016):** Loosen the thumb screw on the eyepiece holder located on the focuser draw tube. Slide the smaller end of the diagonal (without the thumb screw) into the focuser tube. Tighten the thumb screw to hold the diagonal in place.

**Ocular:** Loosen the thumb screw on the eyepiece holder (or 1 ¼" diagonal for #21077 & #21016). Slide the barrel of the eyepiece into the eyepiece holder and tighten the thumb screw to hold the eyepiece in place.

### Aligning the Finderscope

Accurate alignment of the finderscope makes it easy to find objects with the telescope, especially celestial objects. To make aligning the finderscope as easy as possible, this procedure should be done in the daytime when it is easy to find and identify objects. To align the finder:

1. Choose a target that is in excess of one mile away. This will eliminate any possible parallax effect between the telescope and finderscope.
2. Point the telescope at your target and center it in the main optics of the telescope. You may have to move the telescope slightly to center your target.
3. Adjust the screws on the finderscope bracket, tightening one while loosening another, until the cross hairs are centered on the target seen through the telescope.
4. Tighten the lock nuts to secure the position of the finderscope.

Image orientation through the finder will be inverted (i.e., upside down and backwards left-to-right). This is normal for any finderscope that is used straight-through. Because of this, it may take a few minutes to familiarize yourself with the directional change each screw makes on the finderscope.

# Telescope Basics

## Calculating Magnification

The magnification (or power) of a telescope is variable depending upon the focal length of the eyepiece being used along with the focal length of the telescope.

To calculate the magnification we use the following formula:

$$\text{Magnification} = \frac{FL(\text{telescope})}{FL(\text{eyepiece})}$$

where FL(telescope) is the focal length of the telescope and FL(eyepiece) is the focal length of the eyepiece. For example, if the focal length of the telescope is 910mm and you use a 20mm eyepiece your magnification is  $910/20 = 46x$ .

There are numerous optional eyepieces that are available to expand your range of magnification. There are various types of eyepieces of varying quality to choose from.

## The Celestial - Coordinate System.

The celestial-coordinate system is an imaginary projection of the Earth's geographical coordinate system onto the celestial sphere which seems to turn overhead at night. This celestial grid is complete with equator, latitudes, longitudes and poles.

The Earth is in constant motion as it rotates on its axis. Actually the celestial-coordinate system is being displaced very slowly with respect to the stars. This is called precession and is caused by gravitational influences from the Sun, Moon and other celestial bodies.

The celestial equator is a full 360° circle bisecting the celestial sphere into the northern celestial hemisphere and the southern celestial hemisphere. Like the Earth's equator, it is the prime parallel of latitude and is designated 0°.

The celestial parallels of latitude are called "coordinates of declination (Dec.)", and like the Earth's latitudes they are named for their angular distances from the equator. These distances are measured in degrees, minutes and seconds of arc. There are 60 minutes of arc in each degree, and 60 seconds of arc in each arc minute. Declinations north of the celestial equator are "+" and declinations south are "-". The north pole is +90 and the south pole is -90 .

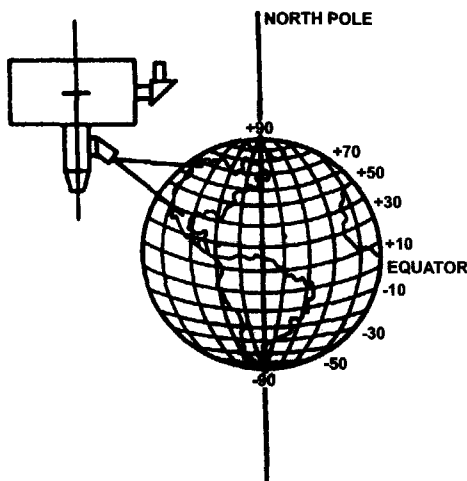

Figure 5

The celestial meridians of longitude are called "coordinates of right ascension (R.A.)", and like the Earth's longitude meridians they extend from pole to pole. There are 24 major RA. coordinates, evenly spaced around the 360° equator, one every 15°. Like the Earth's longitudes, R.A. coordinates are a measure of time as well as angular distance. We speak of the Earth's major longitude meridians as being separated by one hour of time because the Earth rotates once every 24 hours (one hour = 15°). The same principle applies to celestial longitudes since the celestial sphere appears to rotate once every 24 hours. Right ascension hours are also divided into minutes of arc and seconds of arc, with each hour having 60 minutes of arc and each arc minute being divided into 60 arc seconds.

Astronomers prefer the time designation for R.A. coordinates even though the coordinates denote locations on the celestial sphere, because this makes it easier to tell how long it will be before a particular star will cross a particular north-south line in the sky. So, R.A. coordinates are marked off in units of time eastward from an arbitrary point on the celestial equator in the constellation Pisces. The prime R.A. coordinate which passes through this point is designated "0 hours 0 minutes 0 seconds". We call this reference point the vernal equinox where it crosses the celestial equator. All other coordinates are names for the number of hours, minutes and seconds that they lag behind this coordinate after it passes overhead moving westward.

Given the celestial coordinate system, it now becomes possible to find celestial objects by translating their celestial coordinates using telescope pointing positions. For this you use setting circles for R.A. and Dec. to find celestial coordinates for stellar objects which are given in star charts and reference books.

## Polar Alignment

Polar alignment is the process by which the telescope's axis of rotation is aligned (made parallel) with the Earth's axis of rotation (see figure 7). Once aligned, a telescope with a motor drive will track the stars as they move across the sky. The result is that objects being observed through the telescope appear stationary (i.e., they will not drift out of the field of view). If your telescope does not use a motor drive, all celestial objects in the sky (day or night) will slowly drift out of the field. This motion is caused by the Earth's rotation. Even if you are not using a motor drive, polar alignment is still desirable since it will reduce the number of corrections needed to follow an object and limit all corrections to one axis (R.A.). There are several methods of polar alignment, all of which work on a similar principle, but are performed somewhat differently.

For each hemisphere, there is a point in the sky around which all the other stars appear to rotate. These points are called the celestial poles and are named for the hemisphere in which they reside. For example, in the northern hemisphere all stars appear to move around the north celestial pole (see figure 6). When the telescope's polar axis is pointed at the celestial pole, it is parallel to the Earth's rotational axis.

Many of the methods of polar alignment require that you know how to find the celestial pole by identifying stars in the area. For those in the northern hemisphere, finding the celestial pole is not difficult. Fortunately, we have a naked eye star less than a degree away. This star, Polaris, is the end star in the handle of the Little Dipper. Since the Little Dipper (technically called Ursa Minor) is not one of the brightest constellations in the sky, it may be difficult to locate, especially from urban areas. If this is the case, use the two end stars in the bowl of the Big Dipper. Draw an imaginary line through them toward the Little Dipper. They will point to Polaris. The position of the Big Dipper will change during the year and throughout the course of the night. When the Big Dipper is low in the sky (i.e., near the horizon) it may be difficult to locate.

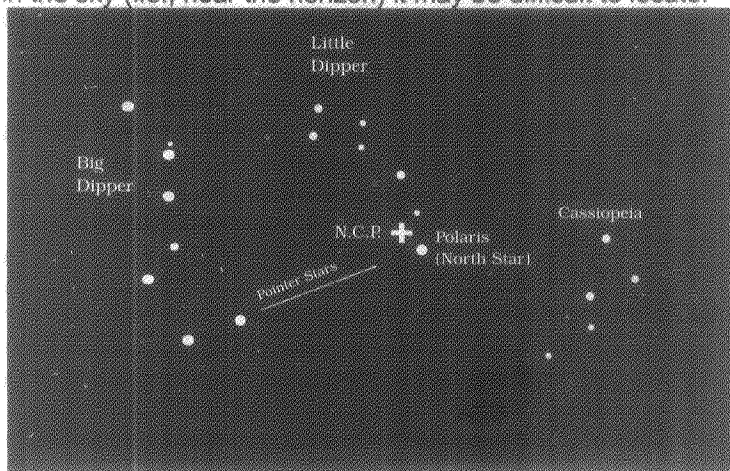

Figure 6

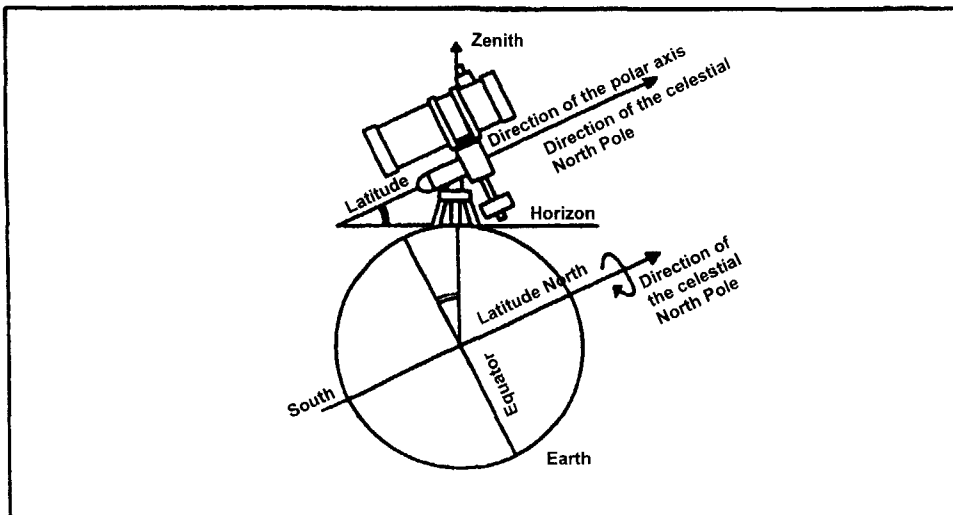

Figure 7

To make finding and tracking the stars easier, a rough polar alignment is required.

1. The right ascension (polar) axis should be pointed towards the North Pole (see figure 7).
2. The equatorial mount should be level.
3. Set the latitude of the telescope to the latitude of your observing location by turning the azimuth adjustment screws (#14) on the mount. The latitude of your observing location corresponds to the altitude that Polaris will appear to be above the horizon. For example, if you are observing from Los Angeles, which has a latitude of  $34^\circ$ , then the celestial pole (and Polaris) will be  $34^\circ$  above the northern horizon. All a latitude scale does then is to point the polar axis of the telescope at the right elevation above the northern (or southern) horizon.
4. Release the DEC clamp and move the telescope so that the tube is parallel to the polar axis. When this is done, the declination setting circle will read  $+90^\circ$ . If the declination setting circle is not aligned, move the telescope so that the tube is parallel to the polar axis.
5. Using the altitude and azimuth adjustment screws (#14 & #20), move the mount until Polaris is in the field of view of the finderscope. Rough adjustments in azimuth can be made by moving the tripod.
6. Center Polaris using the altitude and azimuth controls. **Remember, do not move the telescope in R.A. and DEC. You want to adjust the direction the polar axis is pointing and you are using the telescope to see where the polar axis is pointing.**

This gets you close to the pole but not directly on it. In order to improve your accuracy for more serious observations and photography Celestron offer an optional Polar Axis Finderscope (#94221) that fits into the polar axis of the mount.

#### Aligning the R.A. Setting Circle

Before you can use the setting circles to find objects in the sky you need to align the R.A. setting circle. The declination setting circle is aligned during the process of polar alignment.

In order to align the R.A. setting circle, you will need to know the names of a few of the brightest stars in the sky. If you don't, they can be learned by using the Celestron Sky Maps (#93722) or consulting a current astronomy magazine.

To align the R.A. setting circle:

1. Locate a bright star near the celestial equator. The farther you are from the celestial pole the better your reading on the R.A. setting circle will be. The star you choose to align the setting circle with should be a bright one whose coordinates are known and easy to look up.
2. Center the star in the finderscope.
3. Look through the main telescope and see if the star is in the field. If not, find it and center it.
4. If you purchased an optional motor drive, start it now so that it will track the star.
5. Look up the coordinates of the star.
6. Rotate the circle until the proper coordinates line up with the R.A. indicator (the zero mark on the vernier scale). The R.A. setting circle should rotate freely.

**NOTE:** Because the R.A. setting circle does **NOT** move as the telescope moves in R.A., the setting circle must be aligned each time you want to use it to find an object. This holds true even if you are using an optional motor drive. However, you do not need to use a star each time. Instead, you can use the coordinates of the object you are currently observing.

Once the setting circles are aligned you can use them to find any objects with known coordinates. The accuracy of your setting circles is directly related to the accuracy of your polar alignment.

1. Select an object to observe. Use a seasonal star chart to make sure the object you chose is above the horizon. As you become more familiar with the night sky, this will no longer be necessary.
2. Look up the coordinates in an atlas or reference book.
3. Hold the telescope and release the DEC clamp.
4. Move the telescope in declination until the indicator is pointing at the correct declination coordinate.
5. Lock the declination clamp to prevent the telescope from moving.
6. Hold the telescope and release the R.A. clamp.
7. Move the telescope in R.A. until the indicator points to the correct coordinate.
8. Lock the R.A. clamp to prevent the telescope from slipping in R.A. The telescope will track in R.A. as long as the motor drive is operating.
9. Look through the finderscope to see if you have located the object.
10. Center the object in the finder.
11. Look in the main optics and the object should be there. For some of the fainter objects, you may not be able to see them in the finder. When this happens, it is a good idea to have a star chart of the area so that you can "star hop" through the field to your target.

This process can be repeated for each object throughout any given night.

## Using the R.A. Vernier Scale

To increase the accuracy of the R.A. setting circle, the mount comes with a vernier. This device allows you to get more precise readings down to one minute of right ascension.

Before we go into the specifics on how to use the vernier, let's take a look at the scale and learn how to read it. First, the zero (0) mark on the vernier is the R.A. indicator and will hereafter be referred to as such. It is on the extreme right end of the vernier scale with the other numbers increasing as you move toward the left.

If the R.A. indicator is right on one of the marks of the R.A. setting circle, then that is the coordinate the telescope is pointing at. The problem arises when the R.A. indicator (zero mark) is in between two of the marks on the R.A. setting circle. If this is the case you will notice that along the vernier scale, one of the marks will line up with one of the marks on the setting circle. This mark indicates the number of minutes that should be added to the R.A. reading of the indicator. Since the indicator is between two R.A. marks, add the minutes to the lower value that the R.A. indicator falls between.

For example, let's say the R.A. indicator (zero mark on the vernier) is just left of the 5h 40m mark. This would place it between the 5h 40m mark and the 5h 50m mark. If you look down the vernier scale, you will see that the "4" is the only mark to line up with any of the marks on the R.A. setting circle (see figure 8). This means that you are 4 minutes to the left of the 5h and 40m mark or more simply at 5h and 44m.

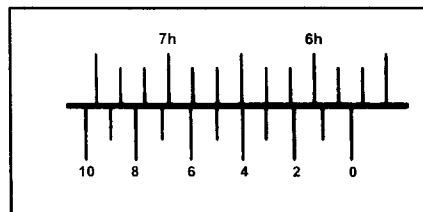

Figure 8

Here's how to use the vernier:

1. Look up the coordinates of the object you want to observe. For our example we will use the Ring Nebula (M57) which is at 18h 53m right ascension.
2. Release the R.A. clamp and rotate the telescope until the R.A. indicator is between the 18h 50m mark and the 19h 00m mark on the R.A. setting circle.
3. Lock the R.A. clamp to hold the telescope in place.
4. Move the telescope in R.A. using the slow motion control handle until the three on the vernier scale lines up with one of the marks on the R.A. setting circle. **Remember, the R.A. indicator must stay between the 18h 50m mark and the 19h 00m mark on the R.A. setting circle!**
5. Look through the telescope and the Ring Nebula should be within the field of view if you are using a low power eyepiece (assuming you have already set the DEC).

## Telescope Maintenance

With proper care your telescope should rarely need any maintenance work.

1. When not in use, always replace all lens covers to keep dust and contaminants off the optical surfaces.

2. A small amount of dust on any optical surface is OK. If the dust builds up then use a can of compressed air and then a camel's hair brush to remove the dust.
3. If the mirrors or lenses need cleaning, they should be cleaned by a professional. Either have your instrument serviced by a telescope repair facility or return it to the factory.
4. Collimation or alignment of the optical system is done at the factory before shipment.

#### **Collimation (for the #31027 and #31056 only)**

1. If your telescope has received very rough handling during transport or is dropped, it may need collimation.

To check if your telescope is in collimation the sketch below will help you. If you look into the eyepiece adapter (without an eyepiece), this is what you should see. If the reflection of your eye is off center, then collimation is necessary.

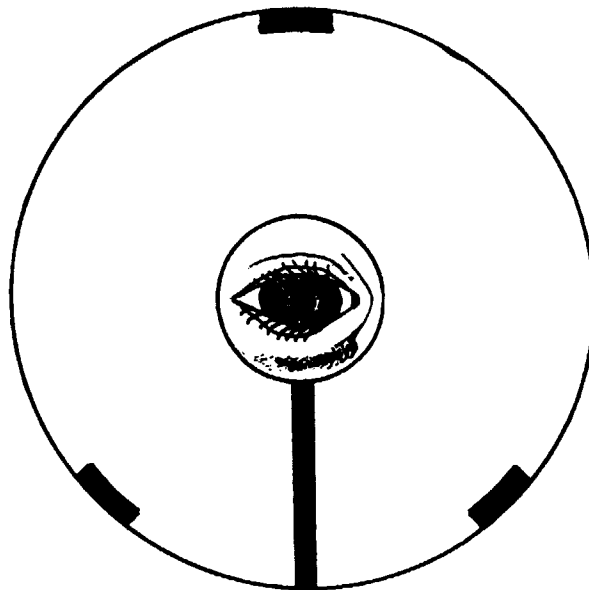

2. If your telescope is out of collimation, it can be re-collimated by loosening the three Phillips head screws located on the rear cell of the telescope tube and adjusting the three knurled knobs until the secondary mirror is centered in the reflection of the primary mirror.

The best way to re-collimate is with a good collimation tool. Celestron offers a Newtonian Collimation Tool (#94183) with detailed instructions that make it an easy chore.

## Technical Specifications

	<b>C80-HD (#21077)</b>	<b>C102-HD (#21016)</b>	<b>C114-HD (#31027)</b>	<b>C150-HD (#31056)</b>
Optical System:	Achromat Refractor	Achromat Refractor	Newtonian Reflector	Newtonian Reflector
Coating:	Fully Multi-Coated	Fully Multi-Coated	Multi-Coated	Multi-Coated
Aperture:	80mm	102mm	114mm	150mm
Focal Length:	900mm	1000mm	900mm	1000mm
F/ratio:	f/11	f/10	f/8	F/7
Magnification (with standard eyepiece)	45x	50x	45x	50x
Highest Useful Power Magnification:	189x	241x	269x	354x
Resolution in arc seconds (Dawes)	1.45	1.14	1.02	0.77
Light Gathering Power:	131	212	265	459
Limiting Visual Magnitude:	12	12.5	13	13.5
Angular Field of View:	1.1°	1°	1.1°	1°
Linear Field of View (at 1000 yds.)	57'	53'	57'	53'
Optical Tube Length:	35"	38.5"	35"	19.25"
Weight				
Optical Tube:	6 lbs.	8.0 lbs.	6 lbs.	13 lbs.
Equatorial Mount (with counterweight):	23 lbs.	28 lbs.	28 lbs.	28 lbs.

Note: All specifications are using the standard accessories. These specifications are approximate and subject to change without notice.

### OPTIONAL ACCESSORIES

Celestron International offers a wide assortment of optional accessories to expand your interests.

**Sky Maps (#93722)** - Invaluable when learning the night sky. They include all the constellations with the brighter deep-sky objects. On the front cover is a rotating planisphere which indicates when specific constellations are visible.

**Flashlight - LED (#93588)** - Uses red LED's to allow reading star maps and locating telescope accessories and controls without ruining your night vision.

**Motor Drive (#93517)**- This single-axis unit runs off D-cell batteries. It compensates for the Earth's rotation keeping celestial objects centered in the field of view. This makes observing much more enjoyable as it eliminates the constant usage of the slow motion controls. A dual-axis model (#93522) is also available.

**Eyepieces** - A whole assortment of various sizes of 1 - 1/4" eyepieces are available to give you a wide range of magnifications.

**Eyepiece filters** - A line of filters are available for 1-1/4" eyepieces to enhance your visual observations of the Moon and planets.

**Collimation Tool for Newtonians (#94183)** - A helpful aid to collimating your telescope. Provided is a simple tool and detailed instructions.

**Polar Axis Finderscope (#94221)** - This useful accessory helps speeds accurate polar alignment by using an etched reticle for finding the North Celestial Pole.

**T-Adapters** - Allows you to take short exposure photos of the Moon. It requires a 35mm SLR camera and a T-Ring for your brand of camera.

Other - Numerous other accessories are available. See the Celestron Accessory Catalog (#93685) or ask your Celestron dealer for details.

## CELESTRON ONE YEAR WARRANTY

- A. Celestron International (CI) warrants this telescope to be free from defects in materials and workmanship for one year. CI will repair or replace such product or part thereof which, upon inspection by CI, is found to be defective in materials or workmanship. As a condition to the obligation of CI to repair or replace such product, the product must be returned to CI together with proof-of-purchase satisfactory to CI.
- B. The Proper Return Authorization Number must be obtained from CI in advance of return. Call Celestron at (310) 328-9560 to receive the number to be displayed on the outside of your shipping container.

All returns must be accompanied by a written statement setting forth the name, address, and daytime telephone number of the owner, together with a brief description of any claimed defects. Parts or product for which replacement is made shall become the property of CI.

**The customer shall be responsible for all costs of transportation and insurance, both to and from the factory of CI, and shall be required to prepay such costs.**

CI shall use reasonable efforts to repair or replace any telescope covered by this warranty within thirty days of receipt. In the event repair or replacement shall require more than thirty days, CI shall notify the customer accordingly. CI reserves the right to replace any product which has been discontinued from its product line with a new product of comparable value and function.

**This warranty shall be void and of no force of effect in the event a covered product has been modified in design or function, or subjected to abuse, misuse, mishandling or unauthorized repair. Further, product malfunction or deterioration due to normal wear is not covered by this warranty.**

CI DISCLAIMS ANY WARRANTIES, EXPRESS OR IMPLIED, WHETHER OF MERCHANTABILITY OF FITNESS FOR A PARTICULAR USE, EXCEPT AS EXPRESSLY SET FORTH HEREIN.

THE SOLE OBLIGATION OF CI UNDER THIS LIMITED WARRANTY SHALL BE TO REPAIR OR REPLACE THE COVERED PRODUCT, IN ACCORDANCE WITH THE TERMS SET FORTH HEREIN. CI EXPRESSLY DISCLAIMS ANY LOST PROFITS, GENERAL, SPECIAL, INDIRECT OR CONSEQUENTIAL DAMAGES WHICH MAY RESULT FROM BREACH OF ANY WARRANTY, OR ARISING OUT OF THE USE OR INABILITY TO USE ANY CI PRODUCT. ANY WARRANTIES WHICH ARE IMPLIED AND WHICH CANNOT BE DISCLAIMED SHALL BE LIMITED IN DURATION TO A TERM OF ONE YEAR FROM THE DATE OF ORIGINAL RETAIL PURCHASE.

Some states do not allow the exclusion or limitation of incidental or consequential damages or limitation on how long an implied warranty lasts, so the above limitations and exclusions may not apply to you.

This warranty gives you specific legal rights, and you may also have other rights which vary from state to state.

CI reserves the right to modify or discontinue, without prior notice to you, any model or style telescope.

If warranty problems arise, or if you need assistance in using your telescope contact:

Celestron International  
Customer Service Department  
2835 Columbia Street  
Torrance, CA 90503  
Tel. (310) 328-9560  
Fax. (310) 212-5835  
Monday-Friday 8AM-4PM PST

This warranty supersedes all other product warranties.

**NOTE: This warranty is valid to U.S.A. and Canadian customers who have purchased this product from an Authorized CI Dealer in the U.S.A. or Canada. Warranty outside the U.S.A. and Canada is valid only to customers who purchased from a CI International Distributor or Authorized CI Dealer in the specific country and please contact them for any warranty service.**

Printed in China 05/99